

2011

# Endotoxin tolerance and the immune system

Marshfield, E.

Marshfield, E. (2011) 'Endotoxin tolerance and the immune system', *The Plymouth Student Scientist*, 4(2), p. 242-251.

<http://hdl.handle.net/10026.1/13958>

---

The Plymouth Student Scientist  
University of Plymouth

---

*All content in PEARL is protected by copyright law. Author manuscripts are made available in accordance with publisher policies. Please cite only the published version using the details provided on the item record or document. In the absence of an open licence (e.g. Creative Commons), permissions for further reuse of content should be sought from the publisher or author.*

# Endotoxin tolerance and the immune system

Elyce Marshfield

*Project Advisor: [Andrew Foey](#), School of Biomedical and Biological Sciences,  
University of Plymouth, Drake Circus, Plymouth, PL4 8AA*

## **Abstract**

Endotoxin tolerance is a phenomenon known to cause innate immune cells, like macrophages, to produce a decreased pro-inflammatory response to a pathogen associated molecular pattern (PAMP), like LPS, after pre-stimulation. Innate immune cells involved have thought to be primarily monocytes/macrophages but evidence has been found for involvement of dendritic cells, neutrophils and T cells. The molecular mechanisms of endotoxin tolerance are vague. However, negative regulators such as SOCS1, IRAK-M and SHIP are believed to play a large role, along with the down-regulation of TLR4 on cell surface and gene re-programming. Clinically, sepsis is a major model of endotoxin tolerance due to the immunosuppression observed; however, new applications for endotoxin tolerance in pathology are becoming apparent, including ischemia-reperfusion injury. Little is known about cross-tolerance, but it does seem to have similarities and differences to homo-tolerance and also application into the clinical world. This review provides an overall picture of findings within endotoxin tolerance from the beginning to recent, including cellular and molecular mechanisms along with clinical applications.

## Introduction

In response to tissue damage or an infection, innate immune cells will secrete many inflammatory mediators to produce an inflammatory response. This occurs through innate cells, such as macrophages, due to the pattern recognition receptors (PRR) they possess on their surface. Toll-like receptor 4 (TLR4) is a member of the PRR family which is responsible for recognising gram-negative bacteria and their endotoxins, such as Lipopolysaccharide (LPS). This recognition allows the initiation of the inflammatory response that is firmly regulated throughout the immune system to prevent uncontrolled inflammation, which can lead to endotoxic shock, tissue damage and pathologies (Beutler, 2004). The immune system has developed a defence mechanism against endotoxic shock thus preventing harmful pathologies like sepsis. Defined as a temporary hypo-responsiveness, endotoxin tolerance (ET) is known as one of these mechanisms (Ishiyama *et al*, 2006). ET is characterised by a reduced production of cytokines when a pro-inflammatory stimulus is incurred. It occurs after an initial low dose of an endotoxin which renders the cell unresponsive when endotoxin is encountered for the second time (Biswas & Lopez-Collazo, 2009). This reduces the toxic effect of high levels of inflammatory mediators (Ishiyama *et al*, 2006). Importance of ET became apparent due to its clinical relevance in severe infections with gram negative bacteria (Beutler, 2004). This review will outline ET and its developments as well as comparing and contrasting more recent literature to give an overview of the effects of ET on the immune system.

## Early Endotoxin Tolerance

The first observations of ET were recorded between the 1930s-40s *in vivo*. The first indication came from human observation, due to patients with neurosyphilis being injected with the typhoid vaccine to induce a fever; however it was also reducing the progression rate of the infection throughout the nervous system (Beutler, 2004). Beeson (1947) investigated this closely and found the constant administration diminished the effect of the vaccine as a pyrogen, thus promoting a higher dose to be given to achieve the original effects. This prompted him to develop a rabbit model where he discovered that tolerance arose from LPS interaction with reticulo-endothelial cells, as the blockade of these cells with trypan blue could prevent tolerance and weaken the removal of the pyrogen from the blood. Additionally, he found that tolerance restricted the response to most gram-negative bacterial pyrogens, and immune competence could be regained when injections were stopped. Freeman (1960) also used a rabbit model, in which he found the plasma of a rabbit expressing tolerance could induce tolerance to bacterial endotoxin when transferred into another animal.

This encouraged human trials, providing more evidence for tolerance. Greisman *et al* (1969) found that the vaccination of live *Salmonella typhosa* in humans promoted a reduction in fever when endotoxin or killed bacteria was encountered compared to prior infected state. Inferences in cross tolerance then became apparent when the same reaction was observed in patients which had been immunised with *Plasmodium cynomolgi* through a bite from a mosquito (Cavaillon & Adib-Conquy, 2006). This experience of reduced immune reaction to endotoxin was found in patients with a variety of infections. *In vivo* observations also provided evidence that ET could restrict the effects of lethal doses of substances in mice. Originally found by Freudenberg and Galanos (1988) who administered mice with a lethal dose of LPS paired with D-galactosamine which enhances the toxicity of LPS. They found pre-treatment with LPS made the mice tolerant to the lethal

dose, even when toxicity was enhanced. They also found that ET was macrophage mediated by transfer of specific cells from LPS tolerant mice to control mice.

### Macrophages and Endotoxin Tolerance

After early *in vivo* studies took place, presumption of cells involved in ET followed, mainly promoting the look into monocytes and macrophages. *In vitro* studies of murine macrophages and human monocytes and ET were undertaken to find the exact function or malfunction which occurs in ET (Biswas & Lopez-Collazo, 2009). When ET is incurred, macrophages show a decrease in secretion of inflammatory cytokines such as TNF $\alpha$ , IL-6, and IL-12, and an increase in secretion of anti-inflammatory cytokines such as IL-10 and TGF- $\beta$  (Fig. 1a). This indicated a decrease in pro-inflammatory macrophage activity (M1) and increase in anti-inflammatory macrophage activity (M2), whilst tolerant monocytes exhibit a M2 response (del Fresno *et al*, 2009). Tolerant macrophages and monocytes have also been found to have reduced antigen presenting function due to the decrease in MHC class II molecule expression like HLA-DRs, along with CIITA, a main regulator of MHC class II expression (Biswas & Lopez-Collazo, 2009). Earlier studies proposed multiple mechanisms for MHC II and co-stimulatory CD86 down-regulation including the involvement of anti-inflammatory cytokines IL-10 and TGF  $\beta$  (Wolk *et al*, 2003). Wolk *et al* (2003) also showed MHC class II down-regulation happened at numerous levels including the invariant chain, HLA-DM, which is responsible for loading the antigenic peptide onto the MHC class II molecule. This is thought to explain the long lasting effects of ET on antigen presentation.

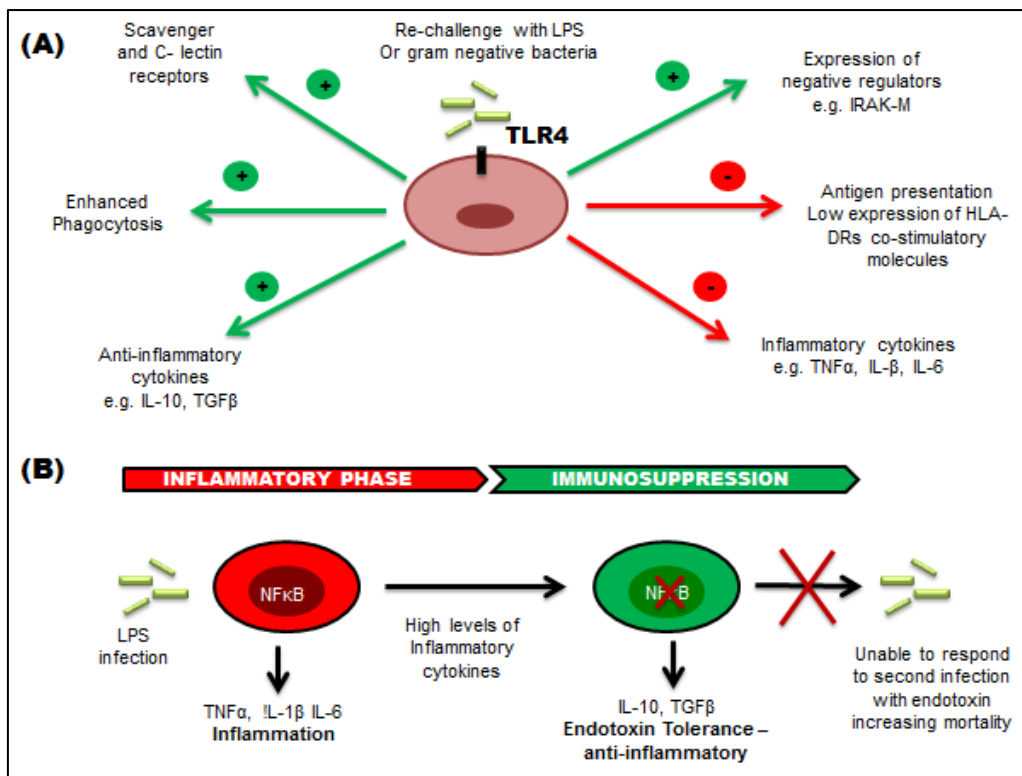

**Figure 1:** Endotoxin tolerance monocyte/macrophage. **(A)** When re-stimulated with gram negative endotoxin (e.g. LPS) show a major down-regulation of pro-inflammatory cytokine production but up-regulation of anti-inflammatory cytokines. Other changes when undergoing tolerance also represented. **(B)** Showing the 2 stages of sepsis in monocytes/macrophages. Endotoxin Tolerance is shown in the 2<sup>nd</sup> stage – immunosuppression.

Adapted from Biswas & Lopez-Collazo (2009).

The lack of antigen presentation prevents an inflammatory response thus making the cell tolerant. However, an increase in the receptor CD64/FcRI, a high affinity Fc IgG receptor on the surface, allows the macrophages to have a higher phagocytic ability (del Fresno *et al*, 2009). Up-regulation of TLR-4 signalling negative regulators such as IRAK-M is also apparent in these cells (Biswas & Lopez-Collazo, 2009). An increase in anti-inflammatory cytokines and increase of phagocytic ability would allow for a more effective bacteria clearance, however, the lack of antigenic presentation would hinder the adaptive response of the macrophages (Fig 1a).

### **Other Cells and Endotoxin Tolerance**

ET is also known to affect other immune cells such as dendritic cells (DCs), neutrophils and T cells. DCs, the most potent of antigen presenting cells (APCs) which have been made tolerant by endotoxin show decreased secretion of IL-12, IL-6 and TNF- $\alpha$ , pro-inflammatory cytokines but increased IL-10 expression and show an increased amount of endocytosis (Albrecht *et al*, 2008). It has also been found that LPS induced tolerance can inhibit APC maturation which was recorded by the inhibition of chemokine production such as CCL3 and CCL5 (Cohen *et al*, 2004). However, Ishiyama *et al* (2006) found NF $\kappa$ B activation is essential for DCs maturation and activation, so when ET is apparent, there is a decrease in overall amount of DCs and activation (Ishiyama *et al*, 2006). Conversely, when neutrophils have been made tolerant by endotoxin they retain their pro-inflammatory cytokine profile, but however do lose expression of TLR4 on their surface (Biswas & Lopez-Collazo, 2009).

DCs have also been related to the induction of specific T helper cells in ET. Ishiyama *et al* (2006) demonstrated in ET there was an increase in myeloid related DCs and therefore a higher amount of antigen presentation, this sways a Th2 response. It also decreases the amount of lymphoid related DCs expressing the antigen presentation molecules which usually promote a Th1 response. Lauw *et al* (2000) also found a favoured Th2 response, however it was due to the cytokine profiles secreted when undergoing ET. They found, once stimulated with LPS, production of Th1 cytokines IFN- $\gamma$  and IL-2 showed a significant decrease in blood samples compared to Th2 cytokines, IL-4 and IL-5 which were not altered or seen to slightly increase. A reduction in Th1 cells would reduce the efficiency of macrophages and prevent the production of CTL's which promote pathogen killing, overall providing a weaker immune response.

ET was also found not just to affect immune cells. Ogawa *et al* (2003) found intestinal micro-vascular endothelial cells usually produce a strong regulatory immune response in gut inflammation. When tolerance was induced, these cells had a severely reduced activation and reduced adhesion of leukocytes to cells preventing an inflammatory response.

### **Molecular Basis of Endotoxin Tolerance**

In immune cells, the aim is to counteract the gram negative bacteria by producing pro inflammatory cytokines. This occurs by LPS binding to the LPS-binding protein (LBP). This complex binds to GPI-CD14 on myeloid cells, such as macrophages. CD14 then presents the LPS/LBP complex to TLR-4 on the cell surface causing it to dimerise (Sly *et al*, 2004). The cytoplasmic tail of TLR-4 contains a TIR domain which, upon dimerization, recruits TIR containing adapter proteins MyD88, TIRAP, TRIF and TRAM (Sly *et al*, 2004). MyD88 and TIRAP then recruit death domain containing serine/threonine kinases IRAK-1 and/or IRAK-4. They also recruit two kinase inactive negative regulators IRAK-2 and IRAK-M. IRAK-1 and IRAK-4 auto-phosphorylate causing them to dissociate from the TLR-4 complex and

bind to TRAF6 (Sly *et al*, 2004). TRAF6 initiates signalling cascades which lead to the activation of p38, Erk, c-Jun, AP1 and NFκB, which, on completion, will initiate pro-inflammatory cytokine synthesis (Sly *et al*, 2004).

TLR-4 can also recruit TRIF in a MyD88 independent method. In this case, TRIF activates NFκB and AP-1 via protein kinases TBK-1 and IKK (Biswas & Lopez-Collazo, 2009). However this process is performed slower than the MyD88 dependant pathway (Sly *et al*, 2004). TRIF also activates the transcription factor IRF3 which up-regulates IFNβ. IFNβ acts through autocrine signalling via a cell surface receptor; this in turn activates the Jak/STAT1 pathway which promotes the transcription of inducible nitric oxide synthase (iNOS) and therefore NO production (Sly *et al*, 2004). Type I IFN's are also thought to up-regulate the anti-inflammatory cytokine IL-10 in macrophages which gives a regulation to the LPS derived response (Chang *et al*, 2007).

The above signalling will take place when the first introduction of LPS occurs, but not in the tolerant state (Fig.2). It is known ET promotes a down-regulation of TLR-4 and a decrease in activation of NFκB, preventing the production of pro-inflammatory cytokines. The mechanisms of ET are vague but research has implicated it is through the action of 3 negative regulators, IRAK-M, SOCS1, and SHIP (Fig.2).

Kobayashi *et al* (2002) showed IRAK-M, produced by TLR-4 signalling, negatively regulates TLR signalling through a MyD88-dependent pathway. This occurred by IRAK-M preventing IRAK-1 and IRAK-4 from dissociating from the TLR-4 complex therefore preventing IRAK-TRAF6 complexes to form, which prevents the consequential signalling cascades that lead to the reduction of pro-inflammatory cytokine synthesis. This was demonstrated in IRAK-M knockout mice, which showed an increase in inflammatory response when presented with bacteria and significantly decreased level of ET when a second dose was administered.

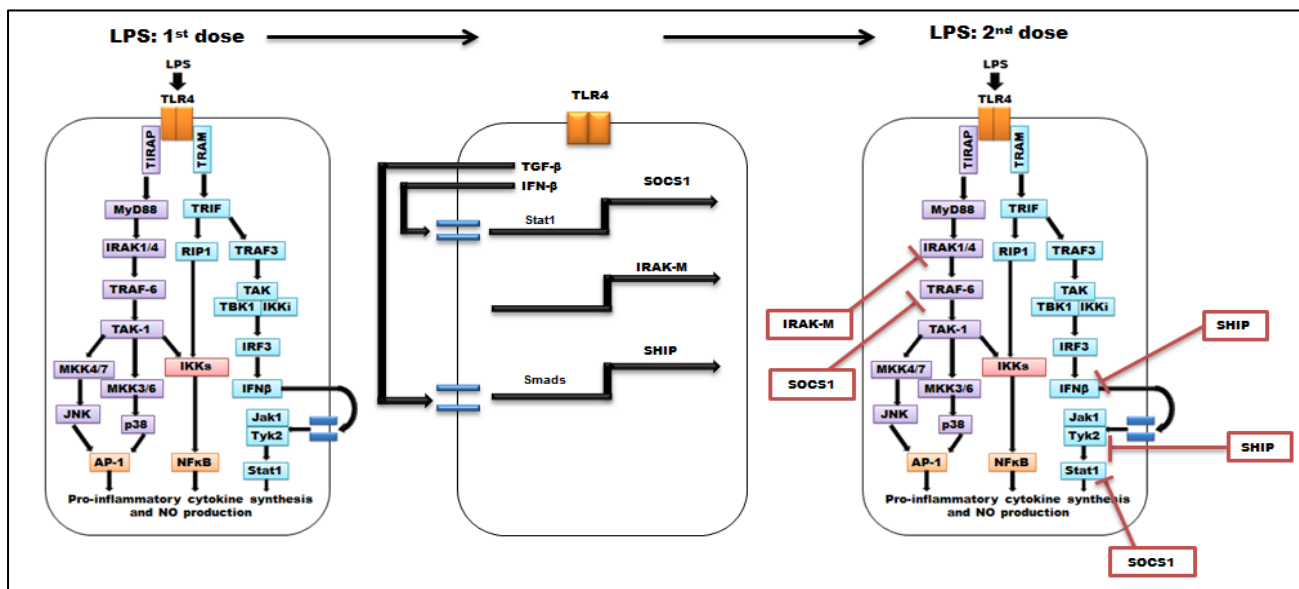

**Figure 2:** Signalling pathways to show model of endotoxin tolerance via TLR4 due to dose of LPS. The first diagram shows usual functioning signalling which occurs on first dose with LPS. The middle shows the activation of inhibitory pathways. The left hand diagram shows the effect of the negative regulators on 2<sup>nd</sup> dose with LPS. Adapted from Sly *et al* (2004).

ET was originally characterised as down-regulation of the MyD88 dependent pathway due to the decrease of pro-inflammatory cytokines, however, the up-regulation of IFN- $\beta$  a TRIF dependant cytokine was also found. Biswas *et al* (2007) investigated the TRIF dependent pathway to see its effects on ET. They found although pro-inflammatory cytokines were down regulated in tolerant cells, the anti-inflammatory cytokine IL-10 and TRIF dependant IFN- $\beta$  were up-regulated. This production was found to correlate with the faulty activation of NF $\kappa$ B whilst TRIF still functioned to promote STAT-1 signalling. This STAT-1 pathway is said to promote the up-regulation of SOCS1, a negative regulator, proposed to inhibit TRAF-6 and the Jak/STAT signalling pathway (Sly *et al*, 2004). Biswas *et al* (2007) also found when a model of TRIF deficiency was used in TRIF knockout mice, the suppression of pro-inflammatory cytokines was dismissed. Additionally, by using IFN- $\beta$  neutralising antibody, LPS tolerance was moderately alleviated, allowing pro-inflammatory cytokine production. However, they did also find that persistent TRIF activation could cause tolerance in cells.

SHIP activation is delayed in cells compared to activation of SOCS1 and IRAK-M. However it has been found that tolerance cannot occur without the activity of SHIP (Sly *et al*, 2004). Beulter (2004) found this *in vivo* by comparing SHIP knockout mice with control mice. In the control mice they found LPS tolerance by recording the decreased activation of NF $\kappa$ B, thus decreased pro-inflammatory cytokine production. In the SHIP knockout mice they found the inhibition of activation not to occur, thus no tolerance to be apparent. Sly *et al* (2004) also indicated that TGF $\beta$ , produced by the cells when LPS apparent, up-regulated SHIP via its autocrine abilities. This was proven by the introduction of TGF $\beta$  neutralising antibodies, which when administered blocked the tolerance affect.

However, other molecules have for recently been indicated to be involved. Chang *et al* (2007) also found a link for IL-10 over expression in tolerant cells. This decreased expression of inflammatory genes like TNF- $\alpha$ . They also found that IL-10 working in an autocrine fashion on the cell can up-regulate SOCS3 expression which decreased the activity of the TRIF pathway by interfering with STAT1 activation. Gene reprogramming has also been found to play a role in ET. This occurs by the chromatin remodelling due to histone methylation induced by LPS, which in turn inhibits gene transcription such as TNF- $\alpha$ . However histone acetylation prevents remodelling allowing genes, such as CCL-5, to remain active (del Fresno *et al*, 2009).

### **Clinical Endotoxin Tolerance**

Clinical significance has been discovered for ET allowing resistant states to tissue damage and infection models including, sepsis, renal ischemia-reperfusion injury, infected thermal injury and haemorrhagic shock (Cavaillon & Adib-Conquy, 2006).

The main model of ET, due to its inflammatory implications and complexity, is sepsis. Sepsis results from a deregulated innate cell immune response subsequent to infection by bacteria (Cavaillon & Adib-Conquy, 2006). The disease has 2 stages (Fig.1b), the initial stage being overt inflammation, known as systemic inflammatory response syndrome (SIRS). SIRS is characterised by an influx of cytokines, systemic inflammation and organ failure (Cavaillon & Adib-Conquy, 2006). SIRS can be infectious or non-infectious. It leads to the later stage, compensatory anti-inflammatory response syndrome (CARS), which is an immuno-compromised state where innate cells are shown to be endotoxin tolerant (Cavaillon & Adib-Conquy, 2006). Blood monocytes derived from sepsis patients prove to be like endotoxin tolerant cells by sharing similar characteristics.

Additionally, these cells from patients have a serious reduction of pro-inflammatory cytokine production (e.g. TNF $\alpha$  and IL-6) when re-stimulated *in vitro*, in comparison to healthy volunteer cells (Draisma *et al*, 2009a). Anti-inflammatory cytokines (e.g. TGF- $\beta$ , IL-10) were found to be up-regulated in these cells, along with down-regulation of MHC class II and co-stimulatory molecules (Draisma *et al*, 2009a). However, some discoveries in this model have not been found *in vitro*; for example, the drastic decrease in cell immune cell numbers in sepsis due to apoptosis of CD4<sup>+</sup> T cells, B cells and follicular DCs which in turn promotes re-infection of the patient (Biswas & Lopez-Collazo, 2009).

Ishiyama *et al* (2006) investigated the clinical relevance of endotoxin tolerant cells and transplantation. They found ET induced in mice restricted proliferation of allogeneic CD4<sup>+</sup> and CD8<sup>+</sup> T cells from which they inferred that ER could hinder antigen presentation, thus preventing rejection of allograft transplantation. From this it can be inferred that ET is not just an inflammatory hypo-responsive state but may also allow endurance of body trauma.

Heeman *et al* (2000) investigated the prevention renal ischemia-reperfusion injury when undergoing ET by pre-treating mice with different LPS concentrations, then removing their right kidney and clamping the vessels of the left. All the different concentrations of LPS prevented lethal renal ischemia-reperfusion injury, whilst 73% of the controls (no LPS pre-treatment) died. They also found the destruction of the kidney tissue was prevented, along with leukocyte infiltration, and a decreased number of apoptotic cells. However the process in which this tolerance occurs is indefinable but known to be connected to macrophages and their associated cytokines.

Conversely, Draisma *et al* (2009b) exhibited a human model of ischemia-reperfusion injury using 14 volunteers and injecting them with an incremental dose of LPS over 5 days. After this, temporary ischemia of forearm circulation was induced by simultaneous hand gripping of non-dominant arm. After reperfusion radioactive labelled annexin A5 was injected intravenously and percentage difference in radioactivity was recorded. They found no significant changes between the results before pre-treatment and after. They also found no difference between this group and the control group, concluding LPS-tolerance doesn't protect from ischemia-reperfusion injury in humans. However this study is only a model of ischemia-reperfusion injury and therefore is not as reliable as the exact study which Heeman *et al* (2000) produced. Nonetheless this is still enough evidence to prevent the application of ET in this clinical field as human lives cannot be put at stake if doubt is apparent.

ET has also been found to be protective against some bacterial and fungal infections. Lehner *et al* (2000) found that mice were infected with *Salmonella enterica* had improved anti-bacterial activity after repetitive doses of LPS and therefore a higher resistance to gram-negative bacteria infections. Evidence of fungal infection protection came from Rayhane *et al* (2000) who found mice which were pre-treated with LPS the infected with a fungal infection (*Cryptococcus neoformans*) had increased survival rates associated with decreased burden of fungi in tissues. They also found decreased cytokine levels in the blood brain and lungs. However, some studies insinuate ET to promote infection by exacerbating the immune systems resistance. Observations have been made to endorse this theory, such as reduced IFN levels after LPS pre-treatment is administered, followed by Newcastle disease virus (Cavaillon & Adib-Conquy, 2006). A decreased clearance of *Pseudomonas aeruginosa* in the lungs after LPS pre-treatment has also been observed supporting this theory (Cavaillon & Adib-Conquy, 2006).



### **Cross-tolerance**

Most research into ET has taken place regarding gram-negative bacteria in terms of LPS/TLR4 tolerance. However, it has also been found pre-treatment with a different TLR ligand or gram-positive bacteria can induce ET, termed as cross-tolerance or hetero-tolerance. Much investigation has taken place involving PAMPs which interact with TLR2, such as Pam3Cys, LTA and MALP-2 (Dobrovolskaia *et al*, 2003). Dobrovolskaia *et al* (2003) found the mechanisms of cross-tolerance to be exhibited much weaker in macrophages than homo-tolerance. However, they did find IKK activity was undisturbed, which indicates the TRIF pathway could still be active. Similarly to homo-tolerance, cross-tolerance has been linked to defective TLR signalling leading to a decrease of IRAK-1 and NFκB activity, promoting reduced pro-inflammatory cytokine synthesis (Buckley *et al*, 2006). However, gram-positive tolerance does not include a decrease in expression of TLR on cell surface and insufficient TLR and MyD88 interactions (Buckley *et al*, 2006). Conversely, cross-tolerance has been found to block the capability for heterodimer mobilisation of NFκB, whereas homo-tolerance shows an overexpression in in NFκB homodimer p50 (Buckley *et al*, 2006). Mechanisms of cross-tolerance have been observed in sepsis patients, for example, monocytes from these patients which have been stimulated *in vitro* with Pam3CysSK4 show an increase in IL-10 production (Cavaillon & Adib-Conquy, 2006). However, exact mechanisms of cross-tolerance remain unknown with many contradictory studies being released leaving no molecule or mechanisms to be discounted.

### **Conclusion**

In summary, a tolerant state to endotoxin is characterised by a decrease in a pro-inflammatory response by innate cells when re-stimulation with endotoxin occurs. From the above discussion, ET can be viewed as a complex phenomenon involving negative feedback responses and gene re-programming. The complexity of it is shown by the multiple layers which allow for the regulation of ET by the involvement of signalling molecules, receptors and chromatin remodelling. Cells other than macrophages have also been implicated in the overall process of ET showing how diverse a response it can be. Much research has been undertaken to provide answers for ET which have promoted the look into the immunosuppressive disease sepsis. Although sepsis has been used as the main model due to the distinct similarities, ET has also been used as a model which seems to protect the body from endotoxic shock and trauma, including kidney ischemia-reperfusion injury. However studies taken place *in vitro* show an increased susceptibility to secondary infections which have proved lethal. Immunosuppressive diseases have many forms and it is yet to be known if ET is involved in them, but mechanisms behind tolerance seem to point that way. This could also be indicated by more cross-tolerance research which would give a wider spectrum of diseases which ET could be involved in and an increased understanding of signalling pathways. Next steps in research would be to address the issues with signalling to pinpoint exact mechanisms that cause homo-tolerance and cross-tolerance, to look into immunosuppressive pathologies to see if ET is apparent and transfer knowledge into the clinical field successfully.

### **References**

Albrecht V, Hofer TPJ, Foxwell B, Frankenberger M & Ziegler-Heitbrock L (2008) Tolerance induced via TLR2 and TLR4 in human dendritic cells: role of IRAK-1, *BMC Immunology*, 9:69.

Beeson PB (1947) Tolerance to bacterial pyrogens I & II, *The Journal of Experimental Medicine*, 86:29–44.

Beutler B (2004) SHIP, TGF $\beta$  and Endo toxin tolerance, *Immunity*, 21(2):134-135

Biswas SK, Bist P, Dhillon MK, Kajiji T, del Fresno C, Yamamoto M, Lopez-Collazo E, Akira S & Tergaonkar V (2007) Role for MyD88-Independent, TRIF Pathway in Lipid A/TLR4-Induced Endotoxin Tolerance, *Journal of Immunology*, 179:4083-4092.

Biswas SK & Lopez- Collazo E (2009) Endotoxin tolerance: new mechanisms, molecules and clinical significance, *Trends in Immunology*, 30(10)475-487.

Buckley JM, Wang JH & Redmond HP (2006) Cellular reprogramming by gram-positive bacterial components: a review, *Journal of Leukocyte Biology*, 80:731-741.

Cavaillon JM & Adib-Conquy M (2006) Bench-to-bedside review: Endotoxin tolerance as a model of leukocyte reprogramming in sepsis, *Critical Care*, 10:233.

Chang EY, Guo B, Doyle SE & Cheng G (2007) Cutting edge: Involvement of the type I IFN production and signalling pathway in lipopolysaccharide-induced IL-10 production, *Journal of Immunology*, 178(11):6705-6709.

Cohen N, Morisset J & Emilie D (2004) Induction of Tolerance by *Porphyromonas gingivalis* on APCs: a Mechanism Implicated in Periodontal Infection, *Journal of Dental Research*, 83(5):429-433.

Del Fresno C *et al* (2009) Potent Phagocytic Activity with Impaired Antigen Presentation Identifying Lipopolysaccharide-Tolerant Human Monocytes: Demonstration in Isolated Monocytes from Cystic Fibrosis Patients, *Journal of Immunology*, 182(10):6494-6507

Dobrovolskaia MA, Medvedev AE, Thomas KE, Cuesta N, Toshchakov V, Ren T, Cody MJ, Michalek SM, Rice NR & Vogel SN (2003) Induction of in vitro reprogramming by toll-like receptor (TLR)2 and TLR4 agonists in murine macrophages: Effects of TLR "homotolerance" versus "heterotolerance" on NF- $\kappa$ B signaling pathway components, *Journal of Immunology*, 170(11):508-519.

Draisma A, Pickkers P, Bouw MPWJM, van der Hoeven JG (2009a) Development of endotoxin tolerance in humans in vivo, *Critical Care Medicine*, 27(4):1261-1267.

Draisma A, de Goeij M, Wouters CW, Riksen NP, Oyen WJG, Rongen GA, Boerman OC, van Deuren M, van der Hoeven JG & Pickkers P (2009b) Endotoxin tolerance does not limit mild ischemia-reperfusion injury in humans in vivo, *Innate Immunity*, 15(6):360-367.

Freeman HH (1960) Passive transfer of tolerance to pyrogenicity of bacterial endotoxin, *The Journal of Experimental Medicine*, 111:453-463.

Freudenberg MA, Galanos C (1988) Induction of tolerance to lipopolysaccharide (LPS)-D-galactosamine lethality by pre-treatment with LPS is mediated by macrophages, *Infection and Immunity*, 56:1352-1357.

Greisman SE, Hornick RB, Wagner HN Jr, Woodward WE, Woodward TE (1969) The role of endotoxin during typhoid fever and tularemia in man, *Journal of Clinical Investigation*, 48:613-629.

Heeman U, Szabo A, Hamar P, Müller V, Witzke O, Lutz J & Philipp T (2000) Lipopolysaccharide Pretreatment Protects from Renal Ischemia/Reperfusion Injury, *American Journal of Pathology*, 156:287-293.

Ishiyama K, Ohdan H, Tokita D, Shishida M, Tanaka Y, Irei T & Asahara T (2006) Induction of endotoxin tolerance inhibits alloimmune responses, *Transplant Immunology*, 16(3-4):158-165..

Kobayashi K, Hernandez LD, Galan JE, Janeway CA, Medzhitov R & Flavell RA (2001) IRAK-M is a Negative Regulator of Toll-like Receptor Signaling, *Cell*, 110(2):191-202.

Lauw FN, ten Hove T, Dekkers PEP, de Jonge E, van Deventer SJH & van der Poll T (2000) Reduced Th1, but Not Th2, Cytokine Production by Lymphocytes after In Vivo Exposure of Healthy Subjects to Endotoxin, *Infection and Immunity*, 68(3):1014-1018.

Lehner MD, Ittner J, Bundschuh DS, van Rooijen N, Wendel A & Hartung T (2000) Improved Innate Immunity of Endotoxin-Tolerant Mice Increases Resistance to *Salmonella enterica* Serovar Typhimurium Infection despite Attenuated Cytokine Response, *Infection and Immunity*, 69(1):463-471.

Ogawa H, Rafiee P, Heidemann J, Fisher PJ, Johnson NA, Otterson MF, Kalyanaraman B Pritchard KA & Binion DG (2003) Mechanisms of endotoxin tolerance in human intestinal microvascular endothelial cells, *Journal of Immunology*, 170(12): 5956–5964.

Rayhane Nm Fitting C, Lortholary O, Dromer F & Cavaillon JM (2000) Administration of Endotoxin Associated with Lipopolysaccharide Tolerance Protects Mice against Fungal Infection, *Infection and Immunity*, 68(6):3748-3753.

Sly LM, Rauh MJ, Kalesnikoff J, Song CH & Krystal G (2004) LPS-induced Upregulation of SHIP is Essential for Endotoxin Tolerance, *Immunity*, 21(2):227-239.